



# Chase Doors "J-Hook" Wall Mount Installation Instructions

Cincinnati Ohio, and Redmond Oregon • Phone Toll Free: 1-800-543-4455 • Fax: 1-800-285-0126 • www.chasedoors.com

## STEP 1

Verify the contents of packages received to insure proper delivery of products and sizes ordered.

Contents:

- 1) Mounting Tracks (See Figure 1)
- 2) Correct Number & Size Strips
- 3) 2 Spacers
- 4) Mounting Fasteners
- 5) Installation Instructions

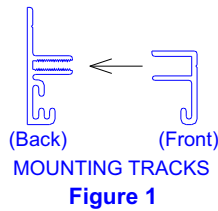

## STEP 2

Place one strip into the Back Mounting Track (see Figure 1-A) and place against the wall above the header. Center the Back Mounting Track with the opening at a height that allows the strip to be 1/4" above the Finished Floor, see Figure 2-A.

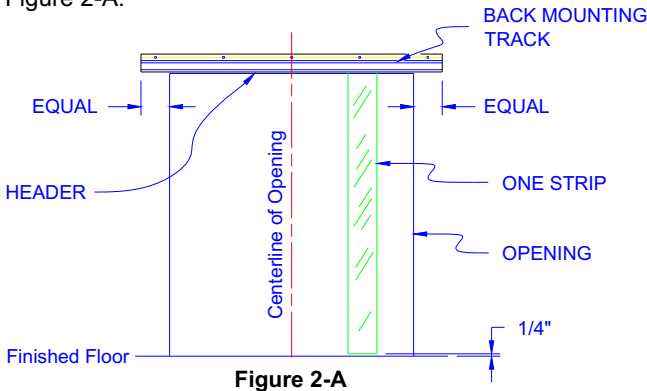

Figure 2-A

Make sure the Back Mounting Track is level. Mark the holes near the top of the Track, see Figure 2-B. Remove Track and Drill appropriate size pilot holes for fasteners being used (use 5/32" Drill Bit for the #10 x 2" Phillips Pan Head Screws included).

Place Back Mounting Track into position and insert the #10 x 2" Pan Head Screws into pilot holes and tighten.

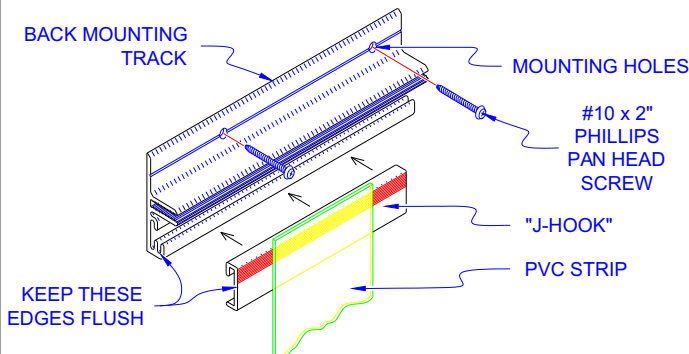

Figure 2-B

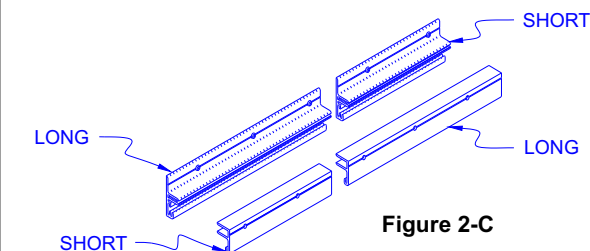

Figure 2-C

## IMPORTANT:

If your application requires two sets of tracking to cover a larger opening, it is recommended that you "Stagger" the Front and Back Tracks as shown in Figure 2-C, This increases strength and stability!

## STEP 3

Clip a "J-Hook" (with strip) into Mounting Track at one end of the Back Track, see Figure 3. Continue placing "J-Hooks" (with strips) end to end until the track is full.

## NOTICE:

**If your final Strip extends past the edge of the Back Track then you will need a Spacer as the final piece. If your final Strip is flush with the edge of the Back Track then you will need to use two spacers on the Front Track (one at each end).**

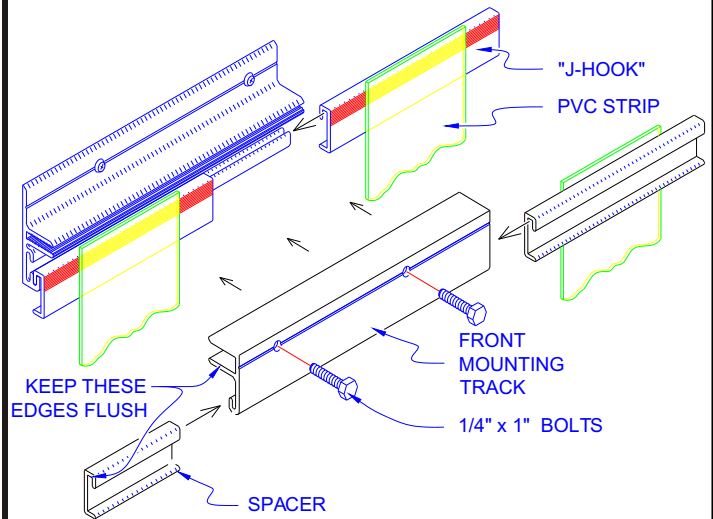

Figure 3

## STEP 4

Hold the Front Mounting Track up to the Back Mounting Track and connect as shown in Figure 1. Insert the 1/4" x 1" Clamping Bolts as shown in Figure 3. Using a 7/16" wrench, or ratchet, tighten to approximately 1/2 turn.

Place one spacer at either end of the Front Mounting Track, see Figure 3. Clip the remaining "J-Hooks" with strips onto the Front Mounting Track against the Spacer, see Figure 4.

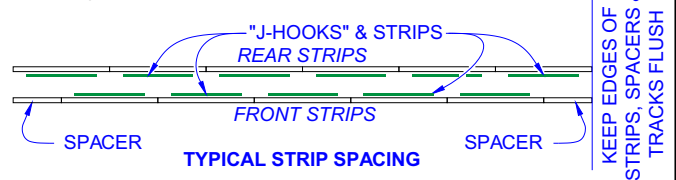

Figure 4

## STEP 5

Tighten the Fasteners on the Front Mounting Track.

**IMPORTANT: DO NOT OVERTIGHTEN THE FASTENERS ON THE FRONT MOUNTING TRACK. THIS WILL CAUSE THE THREADS IN THE BACK MOUNTING TRACK TO STRIP!**